



Pizza Warmer
Model DW-CN-0457-SS
Item 41468
Instruction Manual



Revised - 03/28/2023



Intertek

Intertek

Toll Free: 1-800-465-0234
Fax: 905-607-0234
Email: service@omcan.com
www.omcan.com



Table of Contents

Model DW-CN-0457-SS

Section	Page
General Information -----	3 - 4
Safety and Warranty -----	4 - 6
Technical Specifications -----	6
Operation -----	7 - 9
Maintenance -----	9 - 10
Troubleshooting -----	11 - 12
Parts Breakdown -----	11 - 12
Electrical Schematics -----	13
Notes -----	14
Warranty Registration -----	15



General Information

Omcan Manufacturing and Distributing Company Inc., Food Machinery of America, Inc. dba Omcan and Omcan Inc. are not responsible for any harm or injury caused due to any person's improper or negligent use of this equipment. The product shall only be operated by someone over the age of 18, of sound mind, and not under the influence of any drugs or alcohol, who has been trained in the correct operation of this machine, and is wearing authorized, proper safety clothing. Any modification to the machine voids any warranty, and may cause harm to individuals using the machine or in the vicinity of the machine while in operation.

CHECK PACKAGE UPON ARRIVAL

Upon receipt of an Omcan shipment please inspect for external damage. If no damage is evident on the external packaging, open carton to ensure all ordered items are within the box, and there is no concealed damage to the machine. If the package has suffered rough handling, bumps or damage (visible or concealed), please note it on the bill of lading before accepting the delivery and contact Omcan within 24 hours, so we may initiate a claim with the carrier. A detailed report on the extent of the damage caused to the machine must be filled out within three days, from the delivery date shown in the shipping documents. Omcan has no recourse for damaged products that were shipped collect or third party.

Before operating any equipment, always read and familiarize yourself with all operation and safety instructions.

Omcan would like to thank you for purchasing this machine. It's of the utmost importance to save these instructions for future reference. Also save the original box and packaging for shipping the equipment if servicing or returning of the machine is required.

Omcan Fabrication et distribution Compagnie Limitée et Food Machinery d'Amérique, dba Omcan et Omcan Inc. ne sont pas responsables de tout dommage ou blessure causé du fait que toute personne ait utilisé cet équipement de façon irrégulière. Le produit ne doit être exploité que par quelqu'un de plus de 18 ans, sain d'esprit, et pas sous l'influence d'une drogue ou d'alcool, qui a été formé pour utiliser cette machine correctement, et est vêtu de vêtements de sécurité appropriés. Toute modification de la machine annule toute garantie, et peut causer un préjudice à des personnes utilisant la machine ou des personnes à proximité de la machine pendant son fonctionnement.

VÉRIFIEZ LE COLIS DÈS RÉCEPTION

Dès réception d'une expédition d'Omcan veuillez inspecter pour dommages externes. Si aucun dommage n'est visible sur l'emballage externe, ouvrez le carton afin de s'assurer que tous les éléments commandés sont dans la boîte, et il n'y a aucun dommage dissimulé à la machine. Si le colis n'a subi aucune mauvaises manipulations, de bosses ou de dommages (visible ou cachée), notez-le sur le bond de livraison avant d'accepter la livraison et contactez Omcan dans les 24 heures qui suivent, pour que nous puissions engager une réclamation auprès du transporteur. Un rapport détaillé sur l'étendue des dommages causés à la machine doit être rempli dans un délai de trois jours, à compter de la date de livraison indiquée dans les documents d'expédition. Omcan n'a aucun droit de recours pour les produits endommagés qui ont été expédiés ou cueilli par un tiers transporteur.

General Information

Avant d'utiliser n'importe quel équipement, toujours lire et vous familiariser avec toutes les opérations et les consignes de sécurité.

Omcan voudrais vous remercier d'avoir choisi cette machine. Il est primordial de conserver ces instructions pour une référence ultérieure. Également conservez la boîte originale et l'emballage pour l'expédition de l'équipement si l'entretien ou le retour de la machine est nécessaire.

Omcan Empresa De Fabricacion Y Distribucion Inc. Y Maquinaria De Alimentos De America, Inc. dba Omcan y Omcan Inc. no son responsables de ningun daño o perjuicio causado por cualquier persona inadecuada o el uso descuidado de este equipo. El producto solo podra ser operado por una persona mayor de 18 años, en su sano juicio y no bajo alguna influencia de droga o alcohol, y que este ha sido entrenado en el correcto funcionamiento de esta máquina, y ésta usando ropa apropiada y autorizada. Cualquier modificación a la máquina anula la garantía y puede causar daños a las personas usando la máquina mientras esta en el funcionamiento.

REVISE EL PAQUETE A SU LLEGADA

Tras la recepcion de un envio Omcan favor inspeccionar daños externos. Si no hay daños evidentes en el empaque exterior, Habra el carton para asegurarse que todos los articulos solicitados estén dentro de la caja y no encuentre daños ocultos en la máquina. Si el paquete ha sufrido un manejo de poco cuidado, golpes o daños (visible o oculto) por favor anote en la factura antes de aceptar la entrega y contacte Omcan dentro de las 24 horas, de modo que podamos iniciar una reclamación con la compañía. Un informe detallado sobre los daños causados a la máquina debe ser llenado en el plazo de tres días, desde la fecha de entrega que se muestra en los documentos de envío. Omcan no tiene ningun recurso por productos dañados que se enviaron a recoger por terceros.

Antes de utilizar cualquier equipo, siempre lea y familiarizarse con todas las instrucciones de funcionamiento y seguridad.

Omcan le gustaría darle las gracias por la compra de esta máquina. Es de la mayor importancia para salvar estas instrucciones para futuras consultas. Además, guarda la caja original y el embalaje para el envío del equipo si servicio técnico o devolución de la máquina que se requiere.

Safety and Warranty

WARNING

1. If the supply cord is damaged it must be replaced by Omcan, or a qualified service agent in order to avoid any electrical hazards.
2. This appliance shall not be cleaned with any type of liquid pressurized cleaning equipment.
3. This appliance is not intended for use by persons (including children) with reduced physical, sensory or mental capabilities, or lack of experience and knowledge, unless they have been given specific instruction



Safety and Warranty

with proper supervision concerning the use of this appliance.

4. Under no circumstances should any children be allowed to operate this equipment unless properly supervised.
5. This equipment comes with a properly grounded power cord. All power receptacles should be installed with a properly installed grounded circuit.

SAFE OPERATION NOTICE

- All operators must strictly observe and follow local state or provincial electrical safety codes and guidelines.
- This unit must be used by qualified and trained personnel at all times. Staff should be instructed on proper daily operation and maintenance prior to usage.
- Before operating machine, ensure that all covers, doors and moving components are installed properly and working prior to usage. This will ensure unit is in safe operating order and provide years of long lasting service.

Warranty does not apply to the following conditions:

- Improper uses other than what the unit was originally designed.
- In the case of damaged parts, do not continue to use the unit as you will void the warranty. Contact Omcan or your local dealer.
- Neglect and improper operating procedures during installation and or in transportation, commissioning, maintenance or repair.
- All warranty repairs must be authorized by the original manufacture by means of written consent.
- Warranty parts can be supplied and installed by means of a authorized service agent hired or contracted by Omcan only. Unauthorized service will void all warranties without prior written consent from Omcan. Improper daily maintenance.
- Use of Force Majeure.

ELECTRICAL

When first installed, ensure proper power requirements are met. A standard 15A / 110-120V grounded receptacle must be utilized.

RESIDENTIAL USERS: Vendor assumes no liability for parts or labor coverage for component failure or other damages resulting from installation in non-commercial or residential applications. The right is reserved to deny shipment for residential usage; if this occurs, you will be notified as soon as possible.

1 YEAR PARTS AND LABOUR BENCH WARRANTY

Within the warranty period, contact Omcan Inc. at 1-800-465-0234 to schedule a drop off to either an Omcan authorized service depot in the area, or to an Omcan Service warehouse to repair the equipment.

Unauthorized maintenance will void the warranty. Warranty covers electrical and part failures, not improper use.

Safety and Warranty

Please see <https://omcan.com/disclaimer> for complete info.

WARNING:

The packaging components are classified as normal solid urban waste and can therefore be disposed of without difficulty.

In any case, for suitable recycling, we suggest disposing of the products separately (differentiated waste) according to the current norms.

DO NOT DISCARD ANY PACKAGING MATERIALS IN THE ENVIRONMENT!

Technical Specifications

This pizza warmer is mainly utilized in commercial spaces such as fast-food restaurants, convenience stores along with self-service restaurants and supermarkets.

FEATURES OF OUR PRODUCTS

- The unit comes with two florescent lighting fixtures which increases the view ability of the product being displayed.
- The unit also features adjustable humidity and heat controls which allow greater flexibility to improve overall product freshness and consistency.
- The unit thermostat control allows for even heat during the warming period on all food surfaces.

TECHNICAL SPECIFICATIONS

Model	DW-CN-0457SS
Power	1500 W
Temperature	30 - 90°C / 86 - 194°F
Interior Lights	2 W (LED)
Maximum Pizza Size	18" / 457mm
Electrical	110-120V / 60Hz / 1
Weight	70.5 lbs. / 32 kgs.
Packaging Weight	77 lbs. / 35 kgs.
Dimensions	23.6" x 25.3" x 27.6" / 600 x 642 x 700mm
Packaging Dimensions	27.5" x 27.5" x 29.5" / 698 x 698 x 750mm
Item Number	41468

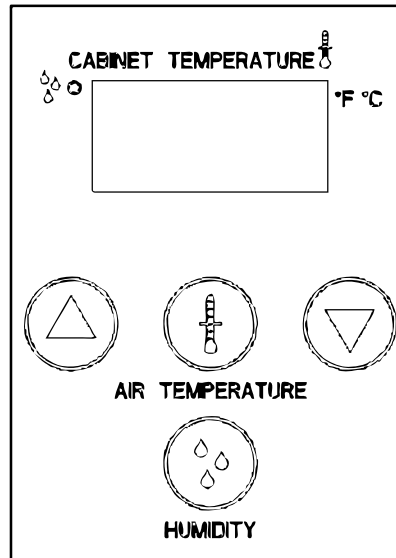

To start:

1. Put plug in power source.
2. Turn the power switch to the "I" position.
 - The display will light up and the heating element will start.
 - "LO H2O" will flash once on the display until water tank is filled with water. Once the tank is full, "LO H2O" will stop flashing and the display will show cabinet temperature.
3. Fill the tank up with water.
 - Turn up the tank cover.
 - Inject water until "LO H2O" stops flashing.

Note: Don't inject water excessively.
4. Set the humidity parameters as required.
5. Set the temperature parameters as required.
6. Please wait 20 minutes before you put food into the machine.

SET TEMPERATURE

1. Press the "⊕" button to start (the display will show "tSP").
 2. Press the "⊕" button again, the display will show current cabinet temperature.
 3. Press "△" or "▽" to modify the temperature. The range is 30°C to 90°C.
 4. Don't press any buttons for 15 seconds, so the temperature setting will be stored. The display will come back to normal mode.
- Note: The temperature values are set to °F when first received, to change between °F and °C please follow the below instructions.**

TO CHANGE THE TEMPERATURE VALUES FROM °F - °C

CAUTION

Ensure that the unit is turned off and removed from it's power source before starting this process.

1. Remove the three screws from the top cover of the machine.

Operation

2. Remove the light tube and its left bracket (Fig. 1).
3. Remove the six screws from the black control box, then remove the cover of the black control box.
4. Locate the switch on the circuit board that shows °F and °C. Switch that part only to change the values from F to C (Fig. 2).
5. Reassemble the machine by following these instructions in reverse order.

Note: please revisit these instructions if you need to change the values back to °F.

FIG. 1

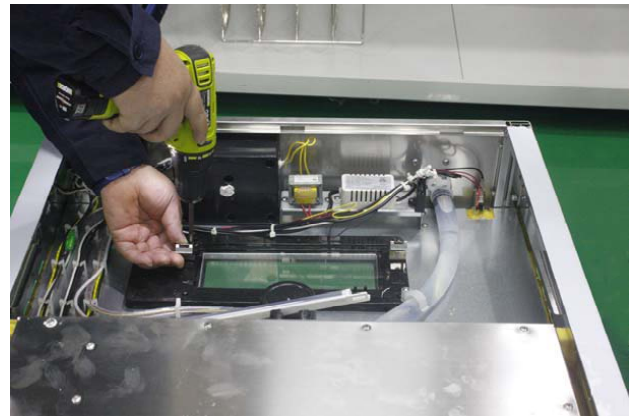
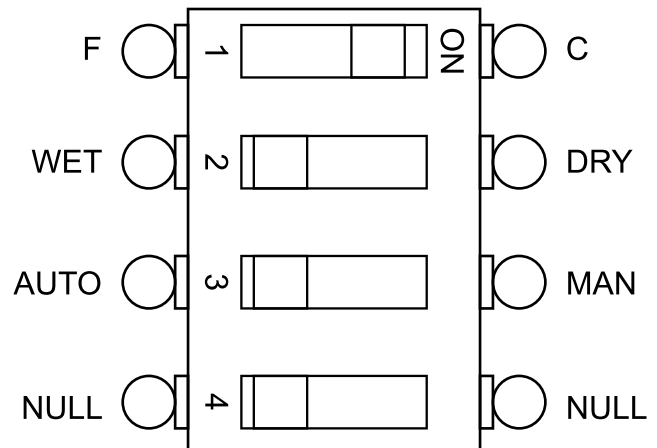
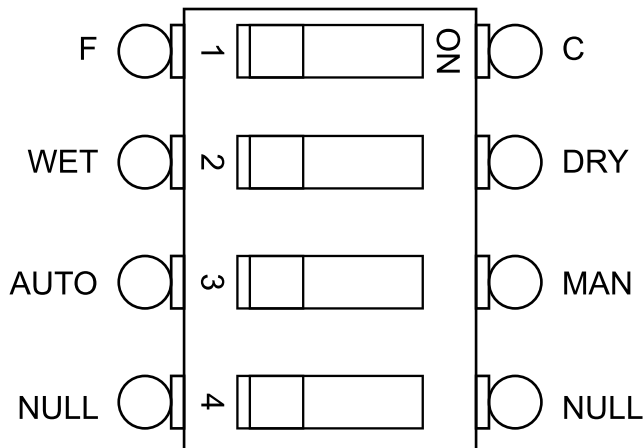





FIG. 2



SET HUMIDITY

1. Press the “” button to start (the display will show “hSP”).
2. Press the “” button again, the display will show current cabinet humidity.
3. Press “” or “” to modify the humidity. The range is 1 to 5.
4. Don't press any buttons for 15 seconds, so the humidity setting will be stored. The display will come back to normal mode.

NOTES

Different kind of food will affect temperature and humidity setting. Temperature on display is the lowest temperature in cabinet, not food temperature.

Full-injected water tank can continuously work for 3 to 6 hours. Working time depends on the different parameter setting, ambient humidity and frequency of door opening. When the display flashes “LO H2O” please add water immediately!

Maintenance

- Daily maintenance should be carried out with all power to the unit in the off position, and the electrical cord unplugged. Cleaning should be carried out by means of food grade cleaning solutions via a soft or damp cloth. Do not utilize any type of pressurized water equipment.
- Regular inspection on the outside and internal cabinet along with the power cord should be observed and carried out on a regular basis to isolate and or observe any unforeseen failure or safety concern.

CLEANING AND INSTALL ROTARY SHELF

1. Open glass door.
2. Loosen top screws.
3. Take out the rotary shelf.

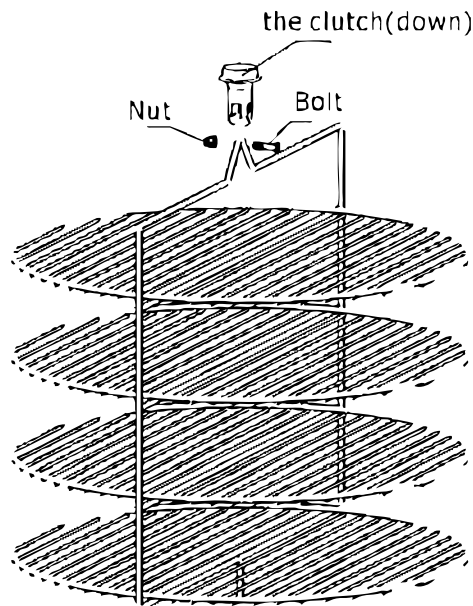

Warning: cleaning outside and inside the cabinet must be made with the power off at all times.

Maintenance

Note: An optional Pretzel Shelf (Omcan Item 44070) is also available and the procedure for assembly/disassembly is the same as above.

Troubleshooting

Problem	Possible Cause	Solution
No lighting in the interior cabinet.	No power.	Inspect power source.
	Florescent lamps failure.	Replace fluorescent tubes.
Rotating shelf has stopped.	Motor damage.	Replace motor.
	Front door not completely closed.	Close front door / check magnetic door sensor.
Interior cabinet heat is not warming up.	Thermostat off.	Dial in temperature.
	Thermostat or heater coil failure.	Contact Omcan.

ERROR CODES

Error Code	Meaning
E1	RT1 (Temperature probe of air inside) is short-circuited or disconnected.
E2	RT2 (Temperature probe of water box) short-circuited or disconnected.
E3	Low water level.
E4	Water level probe is faulty.

Parts Breakdown

Model DW-CN-0457-SS 41468

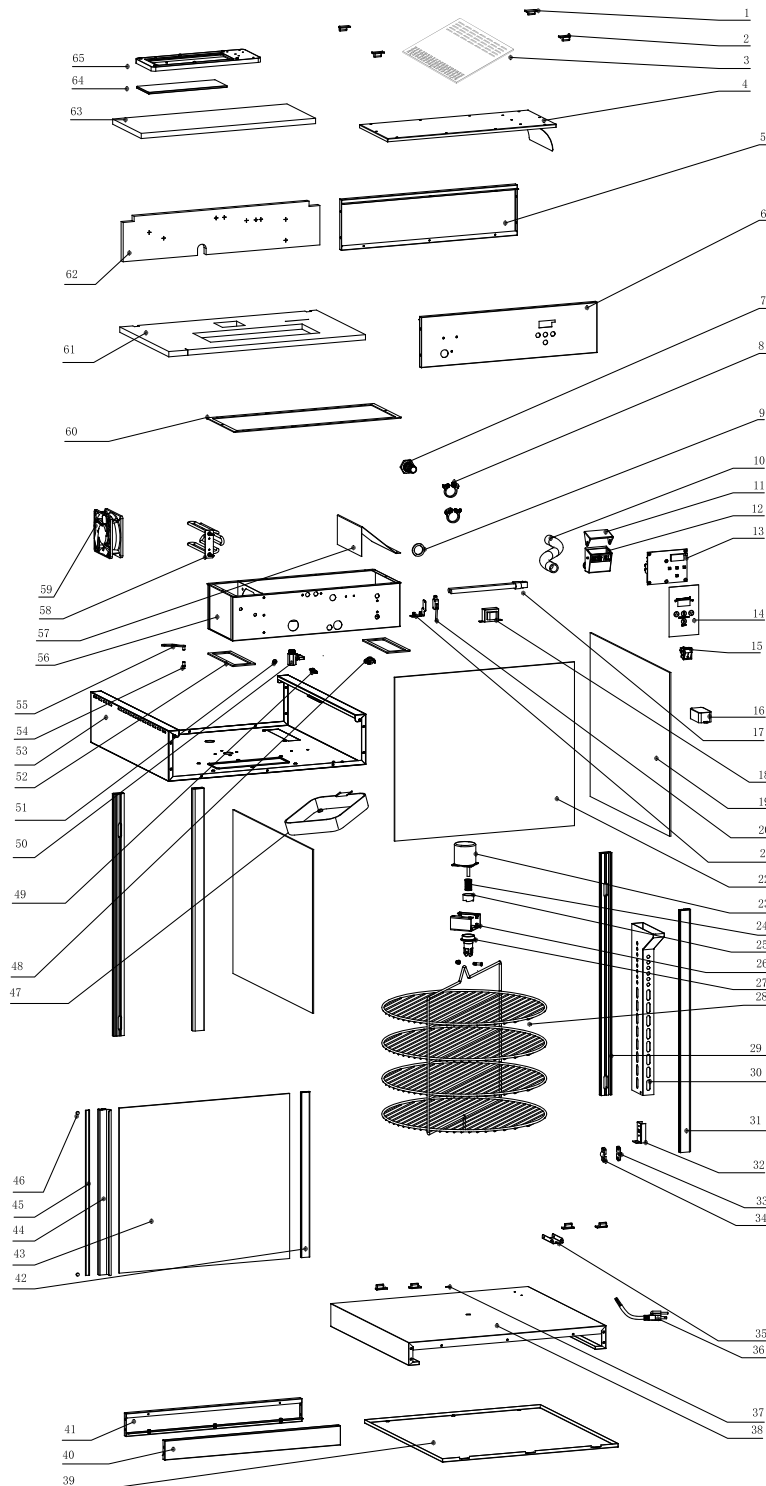

Parts Breakdown

Model DW-CN-0457-SS 41468

Item No.	Description	Position	Item No.	Description	Position	Item No.	Description	Position
70819	Rubber Feet Left for 41468	1	AJ413	Motor for 41468	23	AJ433	Door Magnet Strip for 41468	45
70820	Rubber Feet Right for 41468	2	AJ414	Spring for 41468	24	70866	Magnet for 41468	46
AJ396	Top Cover for 41468	3	AJ415	Upper Clutch for 41468	25	AJ434	Water Box Cover for 41468	47
AJ397	U Cover for 41468	4	AJ416	Motor Bracket for 41468	26	70862	Thermostat T1/33 for 41468	48
AJ398	Rear Top Cover for 41468	5	AJ417	Lower Clutch for 41468	27	AJ435	Temperature Sensor for 41468	49
AJ399	Front Top Cover for 41468	6	AJ418	Rotary Shelf for 41468	28	AJ436	Float for 41468	50
AJ400	Screw for 41468	7	AJ419	Rear Pillar for 41468	29	60212	Double-Faced Protective Ring C6 for 41468	51
AJ401	Top Insulation for 41468	8	AJ420	Wind Guiding Path for 41468	30	AJ437	Seal for 41468	52
AJ402	O Ring for 41468	9	AJ421	Front Pillar for 41468	31	AJ438	Top Panel for 41468	53
AJ403	Inlet Pipe for 41468	10	AJ422	Wires Clip Holder for 41468	32	67295	Door Pin for 41468	54
AJ404	Infall Box Cover for 41468	11	61246	Wire Clip Holder for 41468	33	67296	Upper Hinge Back for 41468	55
AJ405	Infall Box for 41468	12	61245	Wire Clip Cover for 41468	34	AJ439	U Box for 41468	56
AJ406	Circuit Board for 41468	13	AJ423	Wind Guiding Path Bracket for 41468	35	AJ440	U Wind Guiding Panel for 41468	57
AJ407	Operation Sticker for 41468	14	AJ424	Power Plug for 41468	36	AJ441	Heating Element 1 for 41468	58
71514	On/Off Switch (Green) for 41468	15	AJ425	Shelf Bearing for 41468	37	AJ442	Fan Motor for 41468	59
68356	Driver for 41468	16	AJ426	Bottom Cover for 41468	38	AJ443	Seal for 41468	60
AI741	LED Light Tube for 41468	17	AJ427	Bottom Board for 41468	39	AJ444	Bottom Insulation for 41468	61
AJ408	Transformer for 41468	18	AJ428	Front Bottom Panel for 41468	40	AJ445	Front Insulation for 41468	62
AJ409	Side Glass for 41468	19	AJ429	Back Bottom Panel for 41468	41	AJ446	Top Insulation for 41468	63
AJ410	Micro Switch for 41468	20	AJ430	Door Frame for 41468	42	AJ447	Top Light Glass for 41468	64
AJ411	Micro Switch Bracket for 41468	21	AJ431	Door Glass for 41468	43	70844	Transparent Lamp Cover for 41468	65
AJ412	Back Glass for 41468	22	AJ432	Door Handle for 41468	44			

Electrical Schematics

Model DW-CN-0457-SS 41468

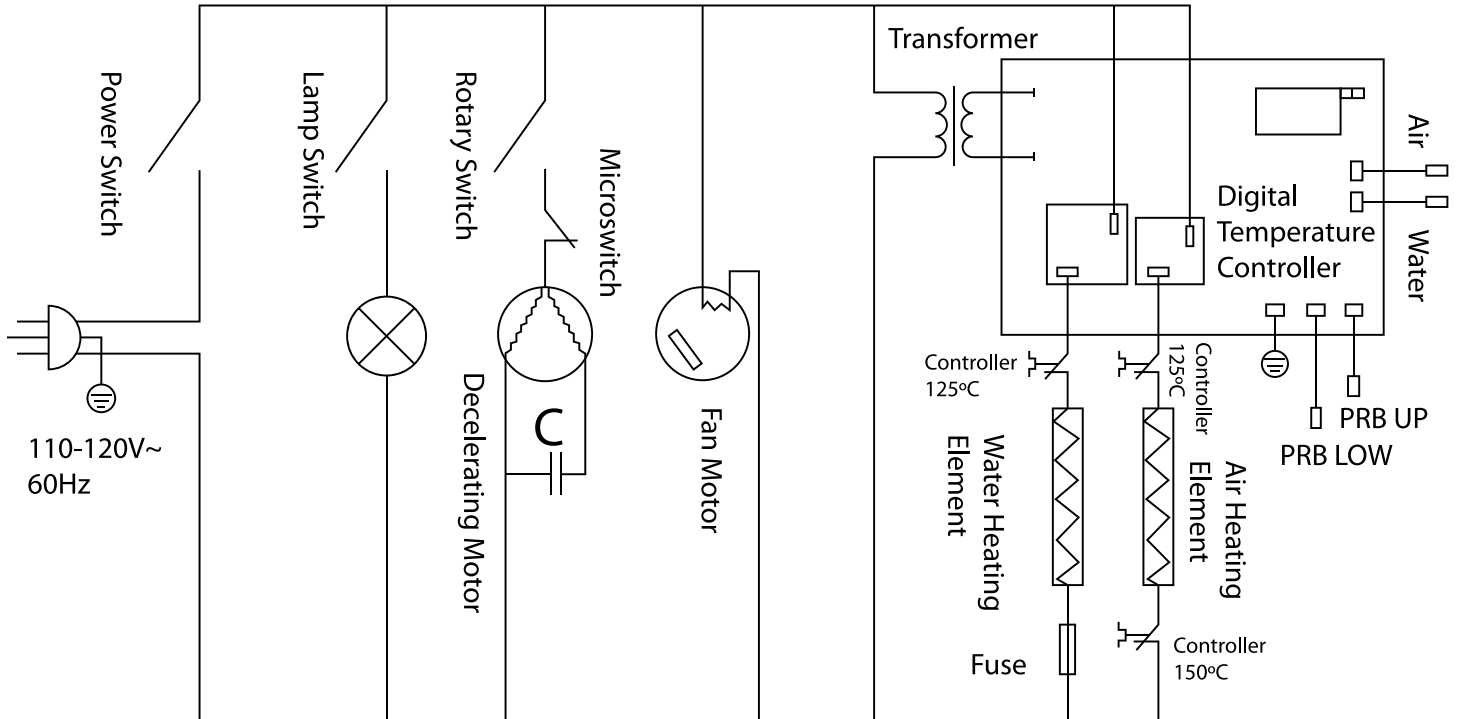

NEMA
5 - 20P
125VAC / 20 AMP



Warranty Registration

Thank you for purchasing an Omcan product. To register your warranty for this product, complete the information below, tear off the card at the perforation and then send to the address specified below. You can also register online by visiting:

Merci d'avoir acheté un produit Omcan. Pour enregistrer votre garantie pour ce produit, complétez les informations ci-dessous, détachez la carte au niveau de la perforation, puis l'envoyer à l'adresse spécifiée ci-dessous. Vous pouvez également vous inscrire en ligne en visitant:

Gracias por comprar un producto Omcan usted. Para registrar su garantía para este producto, complete la información a continuación, cortar la tarjeta en la perforación y luego enviarlo a la dirección indicada a continuación. También puede registrarse en línea en:

<https://omcan.com/warranty-registration/>

For mailing in Canada

Pour postale au Canada

Por correo en Canadá

OMCAN

PRODUCT WARRANTY REGISTRATION

3115 Pepper Mill Court,

Mississauga, Ontario

Canada, L5L 4X5

For mailing in the US

Pour diffusion aux États-Unis

Por correo en los EE.UU.

OMCAN

PRODUCT WARRANTY REGISTRATION

4450 Witmer Industrial Estates, Unit 4,

Niagara Falls, New York

USA, 14305

or email to: service@omcan.com



Purchaser's Information

Name: _____

Address: _____

City: _____ Province or State: _____ Postal or Zip: _____

Country: _____

Dealer from which Purchased: _____

Dealer City: _____ Dealer Province or State: _____

Invoice: _____

Model Name: _____ Model Number: _____

Machine Description: _____

Date of Purchase (MM/DD/YYYY): _____

Would you like to extend the warranty? Yes No

Company Name: _____

Telephone: _____

Email Address: _____

Type of Company:

Restaurant Bakery Deli

Butcher Supermarket Caterer

Institution (specify): _____

Other (specify): _____

Serial Number: _____

Date of Installation (MM/DD/YYYY): _____

Thank you for choosing Omcan | Merci d'avoir choisi Omcan | Gracias por elegir Omcan



Since 1951 Omcan has grown to become a leading distributor of equipment and supplies to the North American food service industry. Our success over these many years can be attributed to our commitment to strengthen and develop new and existing relationships with our valued customers and manufacturers. Today with partners in North America, Europe, Asia and South America, we continually work to improve and grow the company. We strive to offer customers exceptional value through our qualified local sales and service representatives who provide convenient access to over 6,500 globally sourced products.

Depuis 1951 Omcan a grandi pour devenir un des “leaders” de la distribution des équipements et matériel pour l’industrie des services alimentaires en Amérique du Nord. Notre succès au cours de ces nombreuses années peut être attribué à notre engagement à renforcer et à développer de nouvelles et existantes relations avec nos clients et les fabricants de valeur. Aujourd’hui avec des partenaires en Amérique du Nord, Europe, Asie et Amérique du Sud, nous travaillons continuellement à améliorer et développer l’entreprise. Nous nous efforçons d’offrir à nos clients une valeur exceptionnelle grâce à nos ventes locales qualifiées et des représentants de service qui offrent un accès facile à plus de 6500 produits provenant du monde entier.

Desde 1951 Omcan ha crecido hasta convertirse en un líder en la distribución de equipos y suministros de alimentos en América del Norte industria de servicios. Nuestro éxito en estos años se puede atribuir a nuestro compromiso de fortalecer y desarrollar nuevas relaciones existentes con nuestros valiosos clientes y fabricantes. Hoy con socios de América del Norte, Europa, Asia y América del Sur, que trabajan continuamente para mejorar y crecer la empresa. Nos esforzamos por ofrecer a nuestros clientes valor excepcional a través de nuestro local de ventas y representantes de los servicios que proporcionan un fácil acceso a más de 6,500 productos con origen a nivel mundial.

